

Sheet1 (Default)

Item	Part	Rev	Description	Status	Qty	Make or Buy?
1	800544-BCS	00	Tap Assy Commercial - Boiling Chilled Sparkling HydroTap G4	Design	1	Buy
2	875701	A	Assy - Tap (4 in 1)	Production	1	Make
5	A2450	A	Plug - Australian Standard	Production	1	Buy
8	851931	B	Assy - Restrict-A-Flow with ø2.5 Hole	Production	1	Buy
9	802084	A02	"Y" Connector J/G 1/4"	Prototype	1	Buy
10	800221	C	Air Inlet Grill CFF	Production	1	Make
14	83393	A11	Ventilation Grille Hafele	Prototype	1	Buy
17	2855AU	A	Hydro Tap G4 Commercial BCS Compact Base Module Mains/Un/Vented	Production	1	Buy
18	93223	A01	Kit CO2 - 2.6kg Gas+Regulator+Straps	Prototype	1	Buy

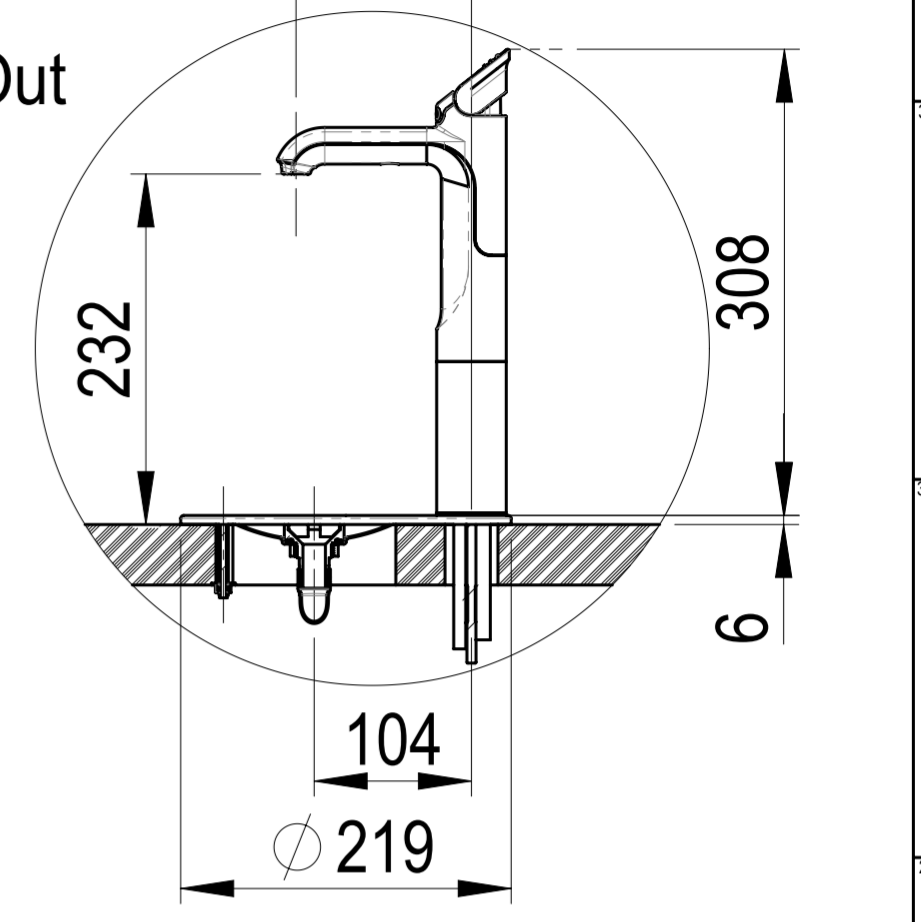

**DETAIL FRONT**  
SCALE 1 : 5

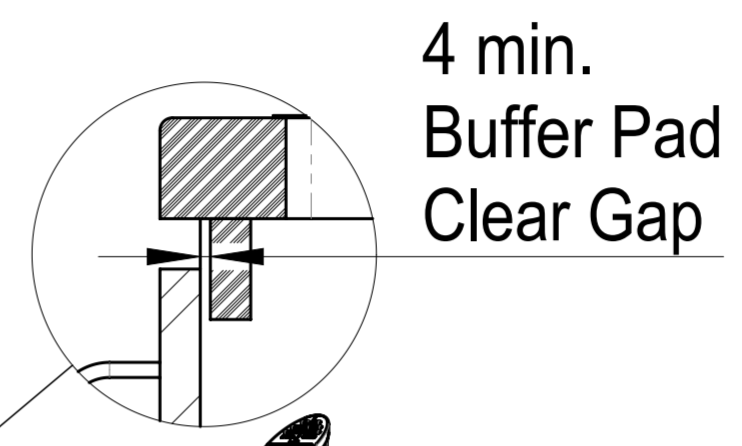
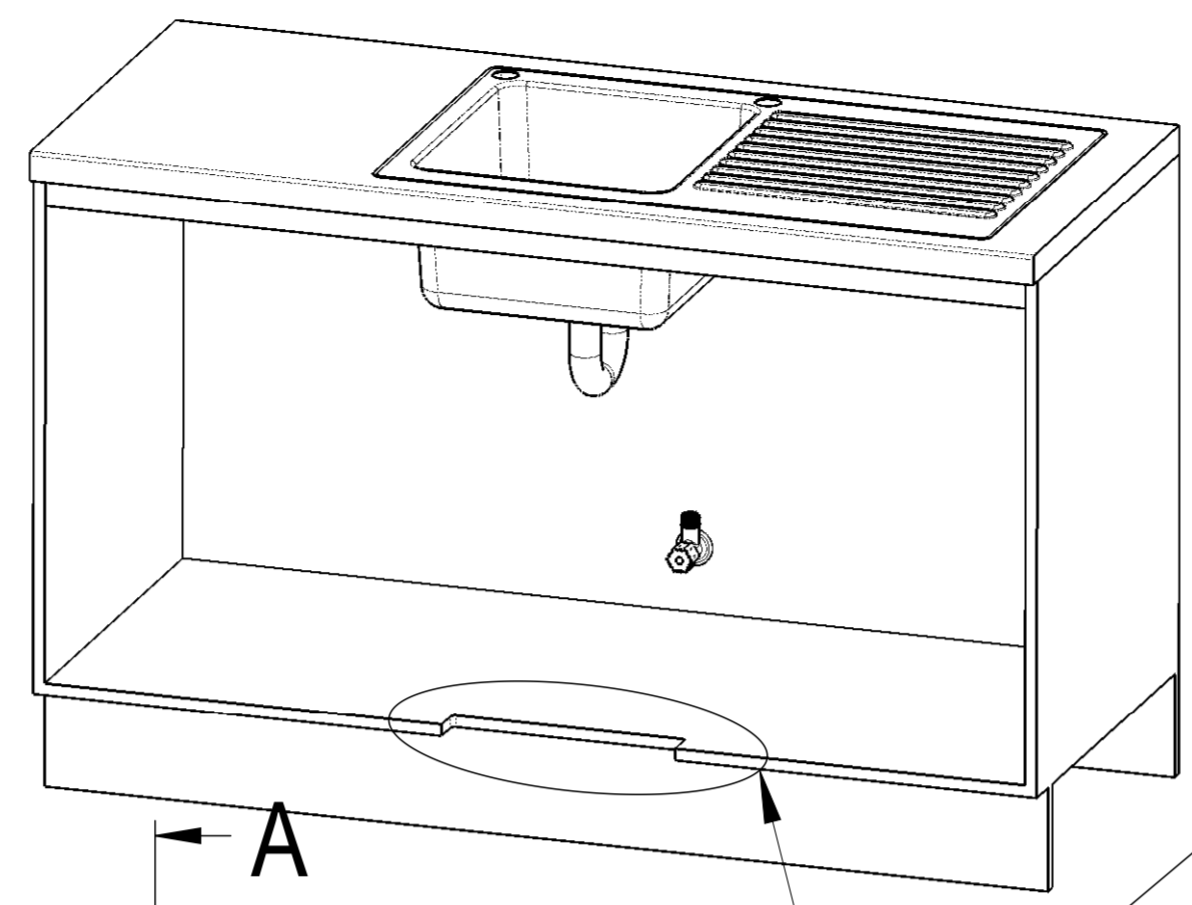
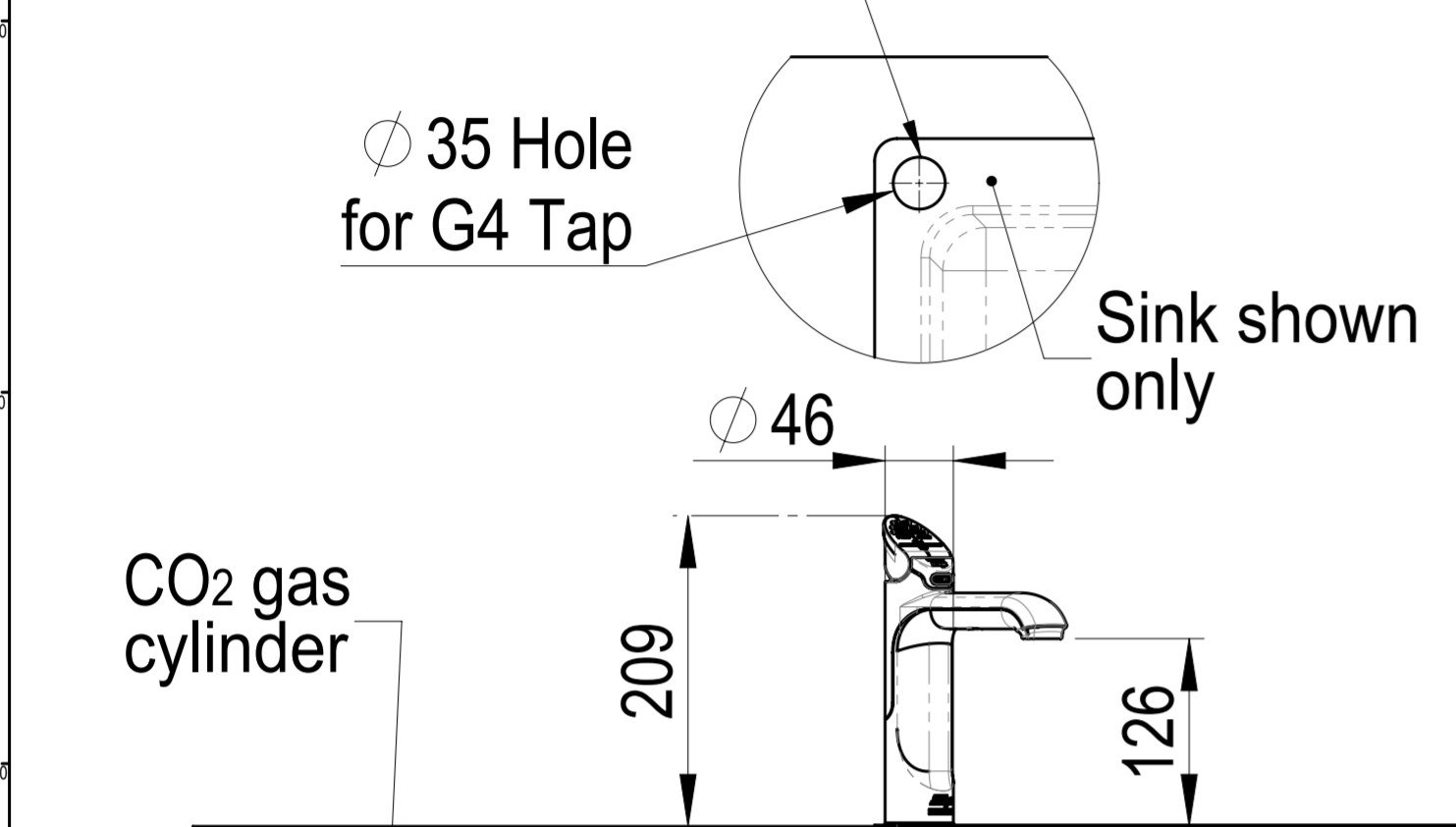
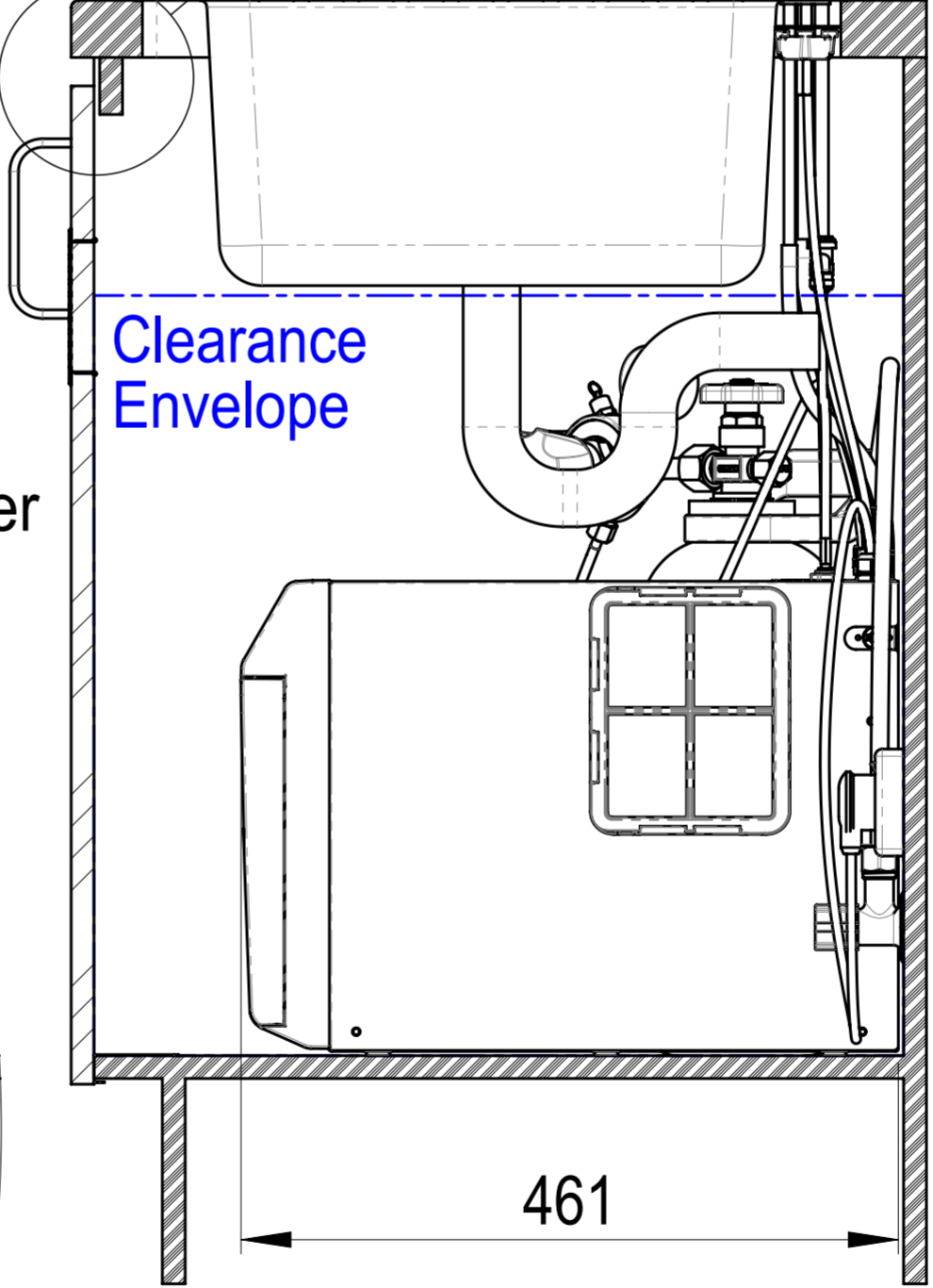
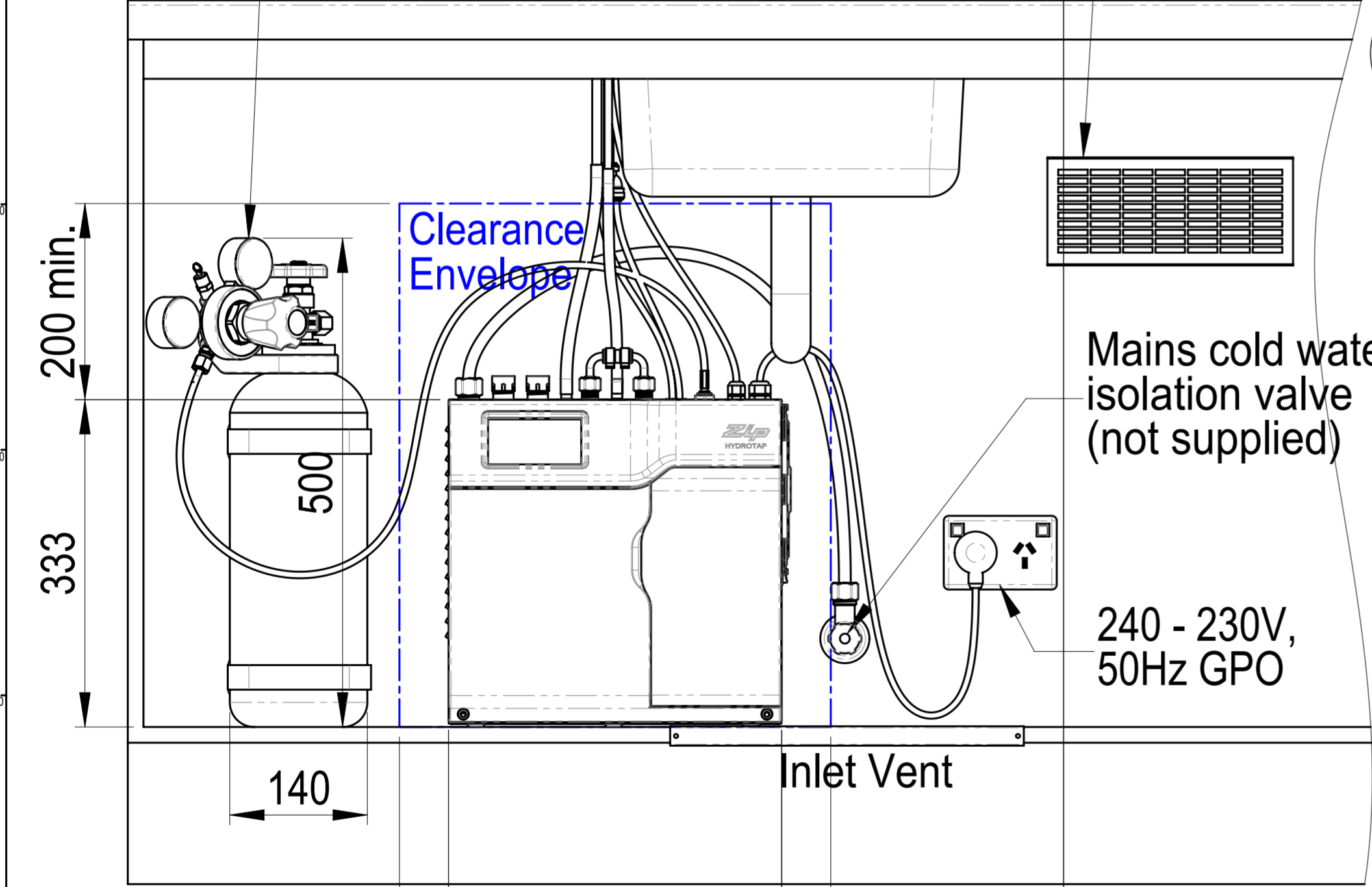

**SECTION A-A**  
SCALE 1 : 5

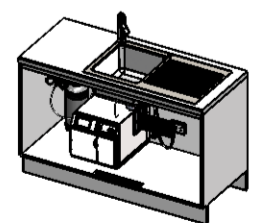
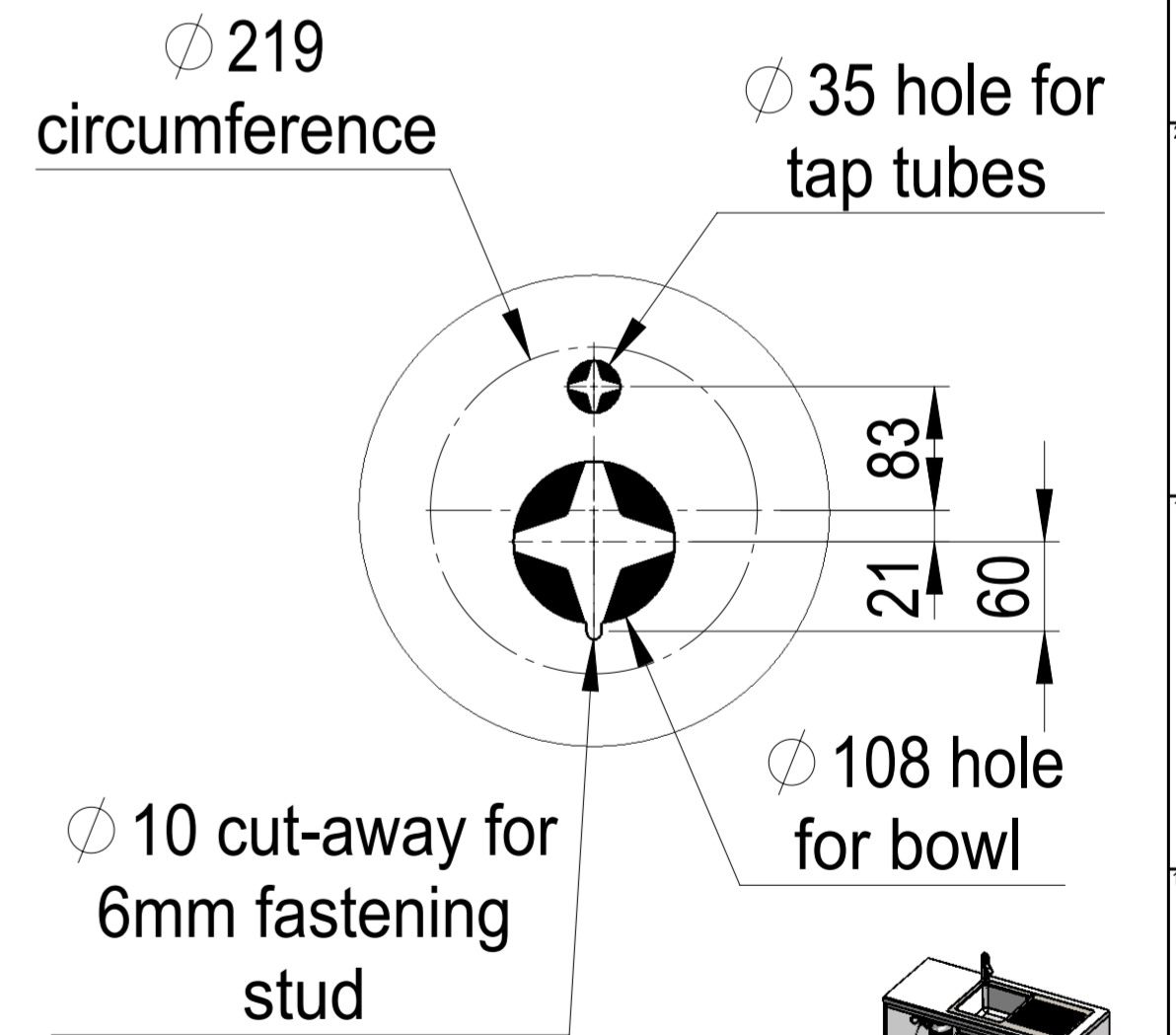

Configuration : Default

This drawing is CONFIDENTIAL and is supplied on the express condition that it shall not be LOANED, COPIED or DISCLOSED to any other third party or used for any purpose without the written consent of Zip Industries Pty Ltd. If this document is printed in hardcopy form, it is for INFORMATION ONLY and therefore not subject to updating controls. For the current revision ALWAYS refer to the NATIVE electronic form as stated in the top left-hand corner of this sheet. © copyright Zip Industries Pty Ltd, 16/05/2011

<b>Manufacturing Instructions</b>		Approved by : edgarg on 4/08/2015	Description :	
Make or Buy : Buy	Checked by : edgarg on 4/08/2015	Asy - Kitchen Layout (HydroTap G4 Commercial BCS Compact & G4 Tap)		
Manufacturing Route : Manufacturing Process		Updated by : edgarg on 5/08/2015 1:59:35 PM	Project : Hydrotap G48	Configuration : Default
Raw material : See Components		Material : See Components	Model : KL002_2855AU0S0Z1C	Created by & on : Edgarg on 4/05/2011
Remove all sharp edges. This drawing ONLY details information which cannot be ascertained from the 2D geometry of the part(s) attached. Model & dimensions are AFTER all finishing operations.		Finish : Finish	Model : KL002_2855AU0S0Z1C	Created by & on : Edgarg on 16/05/2011
Comments :		Finish : Finish	Model : KL002_2855AU0S0Z1C	Rev : 02
Potable? : No	Recyclable? : No	Handed? : No	Volume (mm <sup>3</sup> ) : 81823945.6	Area (mm <sup>2</sup> ) : 130339.3
			Mass (kg) : 90149.1	Density (g/mm <sup>3</sup> ) : 0.0
			Derived from : New	Scale : 1:1
			Colour : Colourless	Sheet : 1 of 1
			Status : Prototype	Part Property
			Drawing Property	Part Property