

Table - Zip BOM (Assembly)

Item	Part	Rev	Description	Config	Status	Default/Qty	Notes
1	A2402	A	Description (Assembly)	For Chhillap & Filter Tap	Production	1	
2	87570!	00	Classic Mixer Tap	Default	Design	1	
3	86451	A	Nipple-Tapered 1/2" (No 27)	Default	Production	3	
4	27920	A	Instantaneous Hot Water CEX-U 13.5kW 3 x 20Amps 60°C	801096	Production	1	
5	84451	A	Tee 1/2" BSP Female (Brass)	Default	Production	1	

Limits unless otherwise stated:		Surface finishes unless otherwise stated:	
1. Fabricated	± 0.75	1. Sand-Cast	± 16.0µm
2. Sand-Cast	± 0.35	2. Drilling	± 6.3µm
3. Forging	± 0.25	3. Forging	± 6.3µm
4. Die-Cast	± 0.25	4. Milling	± 3.2µm
5. Moulded	± 0.15	5. Turning	± 3.2µm
6. Machined	± 0.25mm	6. Boring	± 3.2µm
7. Angular	± 0.50degree	7. Die-Cast	± 1.6µm

THIRD ANGLE PROJECTION

Zip Industries Pty Ltd
67 Allingham Street
Condell Park
Sydney
NSW 2200
Australia

Web: www.zipindustries.com
Email: sales@zipindustries.com

Features marked with this symbol: must be referred to in the manufacturing control plan

REVISIONS				
Rev	XXXX YYYY	Last Change(s)	ECO	Date
A		First Issue	0000	8/06/2011

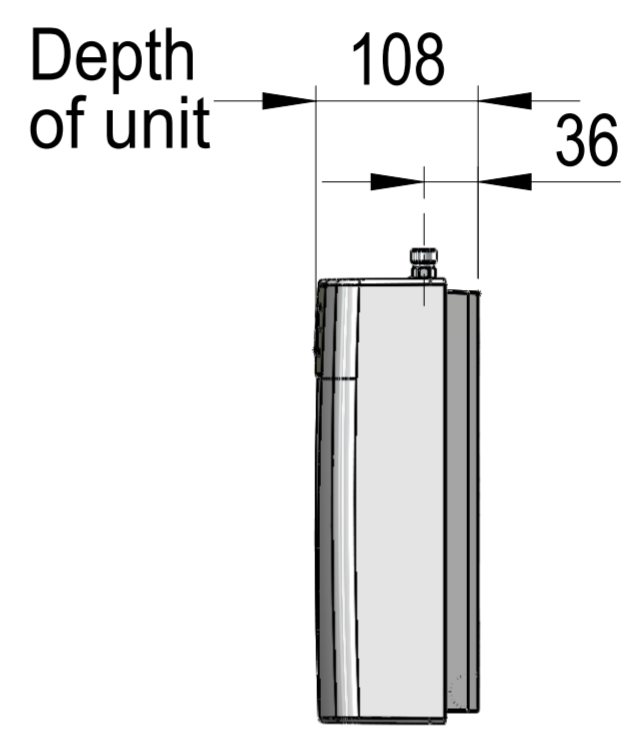
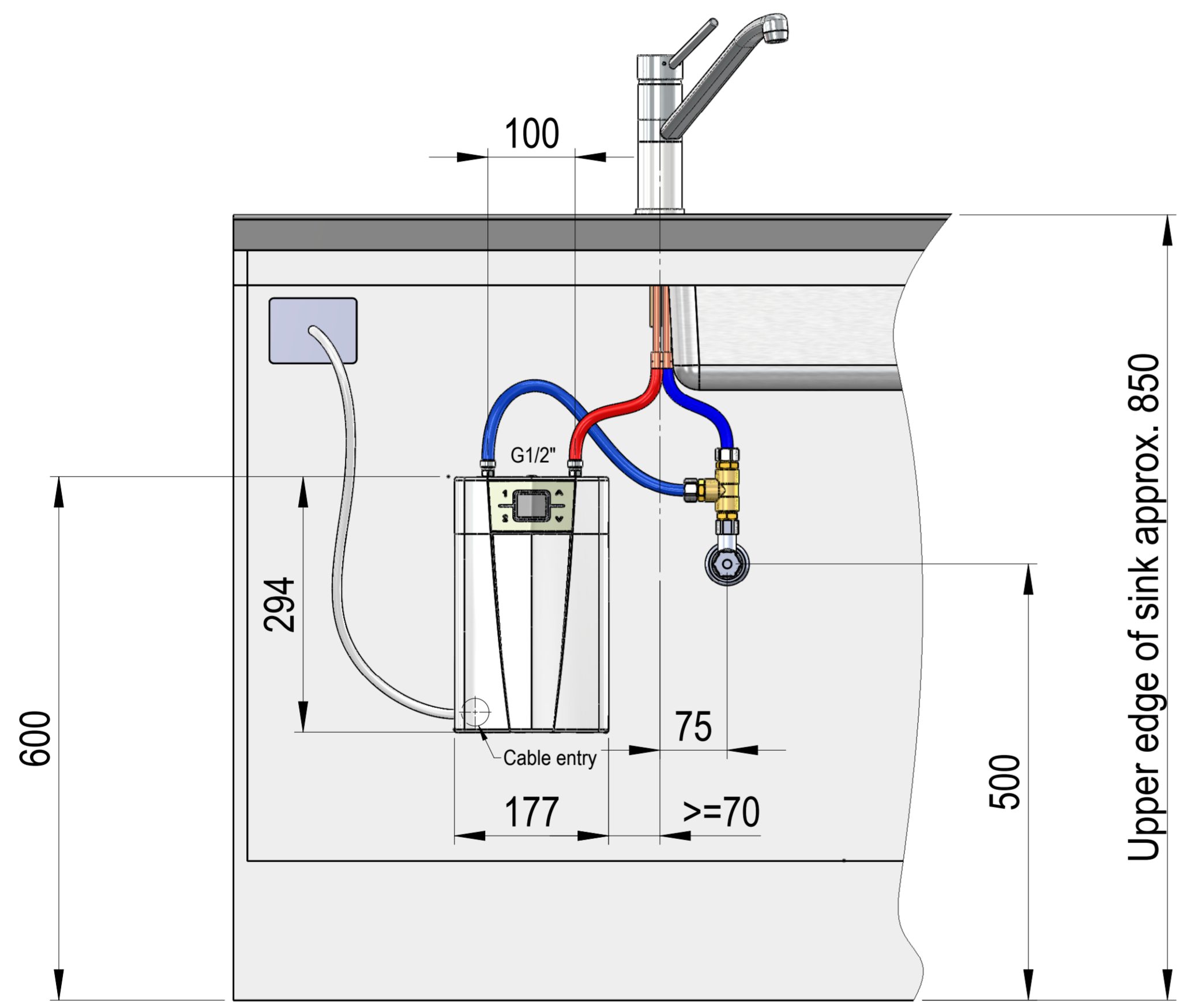

SIDE ELEVATION VIEW
SCALE 1 : 5

This drawing is CONFIDENTIAL and is supplied on the express condition that it shall not be LOANED, COPIED or DISCLOSED to any other third party or used for any purpose without the written consent of Zip Industries Pty Ltd. If this document is printed in hardcopy form, it is for INFORMATION ONLY and therefore not subject to updating controls. For the current revision ALWAYS refer to the NATIVE electronic form as stated in the top left-hand corner of this sheet. © copyright Zip Industries Pty Ltd, 16/05/2011

Zip Industries

Manufacturing Instructions		Approved by: Unapproved on 1/03/2011	Description: Assy - Kitchen Layout Instantaneous Hot Water CEX9-U 8.8kW 38Amps, 50°C
Make or Buy: Make	Checked by: Unchecked on 1/01/2001	Updated by: edgarG on 15/06/2015 7:45:31 AM	Project: Instantaneous Hot Water®
Manufacturing Route: Manufacturing Process	Material: Material <not specified>	Model: WL005_27910	Configuration: Default
Raw material: Raw Material	Finish: Finish	Created by & on: EdgarG on 16/05/2011	Created by & on: EdgarG on 16/05/2011
Remove all sharp edges. This drawing ONLY details information which cannot be ascertained from the 3D geometry of the part(s) attached. Model & dimensions are AFTER all finishing operations.	Volume (mm³): 87279.66	Area (mm²): 114027.95	Derived from: New
Comments: Comments	Mass (kg): 96031.62	Density (g/mm³): 1.10	Scale: 1:1
Potable? No	Recyclable? No	Handed? :	Sheet: 1 of 1
Drawing Property		Part Property	Size: A2